

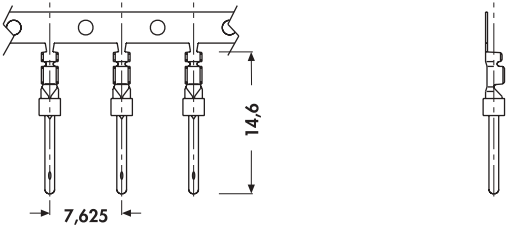



Crimp contacts for D-Sub crimp connectors

Crimp male contacts and crimp female contacts

		
art. no.	crimp area	contact
DC S 20 ...	AWG 20 ... 26	male
DC S 24 ...	AWG 24 ... 28	male
please indicate:	... type of packing: 5 = small chain terminal with 500 contacts, turned left 100 = big chain terminal with 10.000 contacts, turned left	

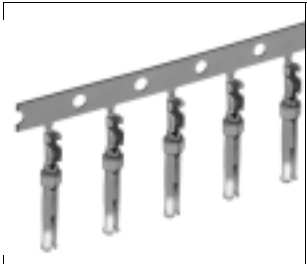
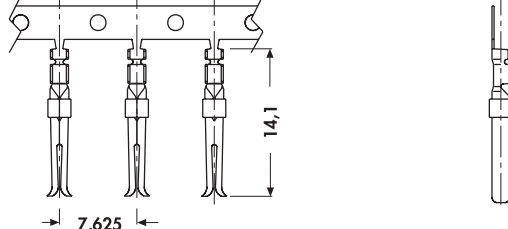
		
art. no.	crimp area	contact
DC B 20 ...	AWG 20 ... 26	female
DC B 24 ...	AWG 24 ... 28	female
please indicate:	... type of packing: 5 = small chain terminal with 500 contacts, turned left 100 = big chain terminal with 10.000 contacts, turned left	

surface finish in contact area: hard gold-plated over nickel (0.1 μm Au over Ni)

crimp area: tin-plated

Crimp hand tool

Usable range: AWG 20 ... 28

art. no. HZ 1

All stressed parts are made from special steel and are heat treated. Plastic coated handles.

Crimp action guaranteed by ratcheted release.